

Automotive Power Management

Driving Optimized Power Performance



AHEAD OF WHAT'S POSSIBLE™

WHY IS AUTOMOTIVE POWER DIFFERENT?



AHEAD OF WHAT'S POSSIBLE™

AUTO ENVIRONMENT IS EXTREMELY UNFRIENDLY TO ELECTRONICS

Temperature Range

Server	50-60°C, all the time
Consumer	-10°C to 70°C, sometimes
Automotive	-40°C to 150°C, thousands of cycles

Noisy, Electrically

Ignition coils, spark plugs, alternator, motors all generate electrical noise

Complex System

Dozens to hundreds of electronic modules and sensors

Interference, Quiescent current

High Quality Expectations

- OEMs require dppb levels of quality
- 100,000 hours lifetime
- Technical considerations in IC design, wafer fab, wafer sort, and final testing

WIDE RANGE OF OPERATING VOLTAGE

The problem with car battery

- What do you think of when you hear “car battery”?
 - > Hint: it’s not a 12V battery
- The actual car battery voltage range:



— Load dump without central suppression: 70V

— Load dump: 36V

— Alternator output: 14.4V

— Fully charged battery: 12.6V

— Drained battery: 11.5V

— Drained & damaged battery: 10.5V

— Cold cranking engine start: 3.5V*

COLD CRANK

- ▶ Start-up
- ▶ Auto Start-Stop – Engine Shut off During a Traffic Stop

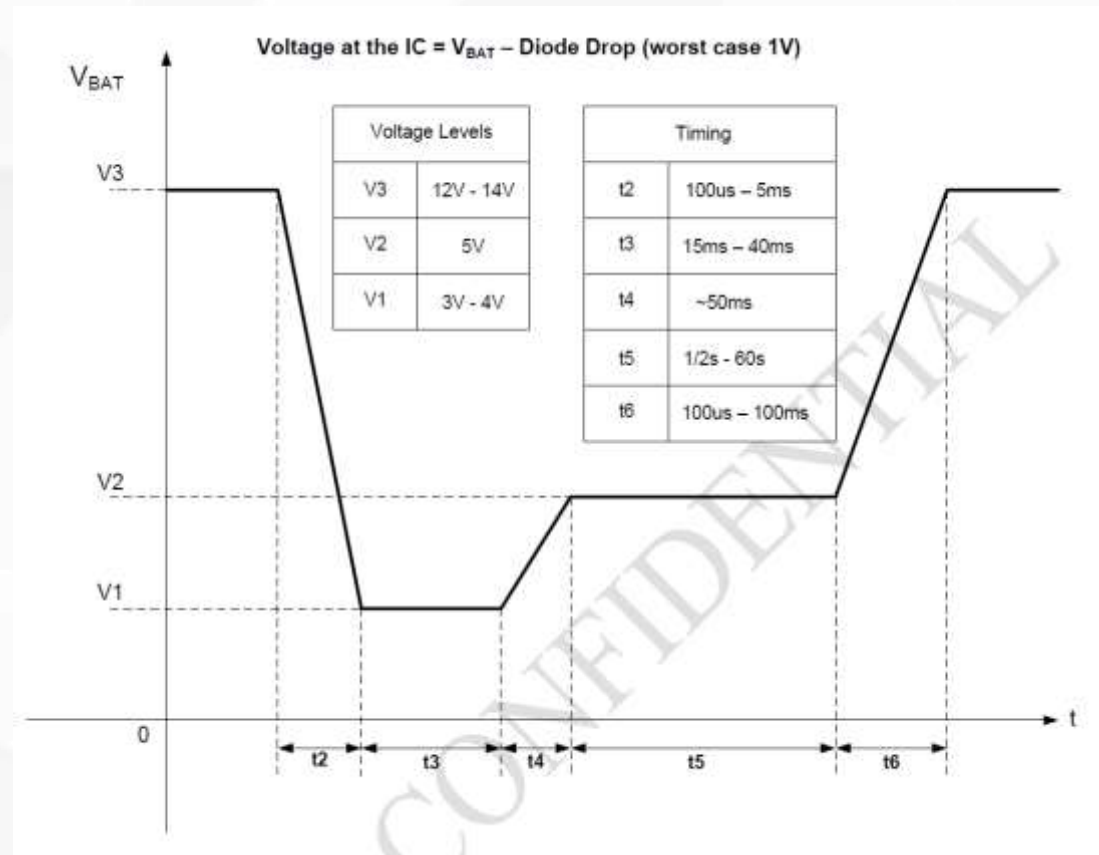

LOAD DUMP

- ▶ Battery Disconnect During Alternator Charging
- ▶ Ignition Switch-off

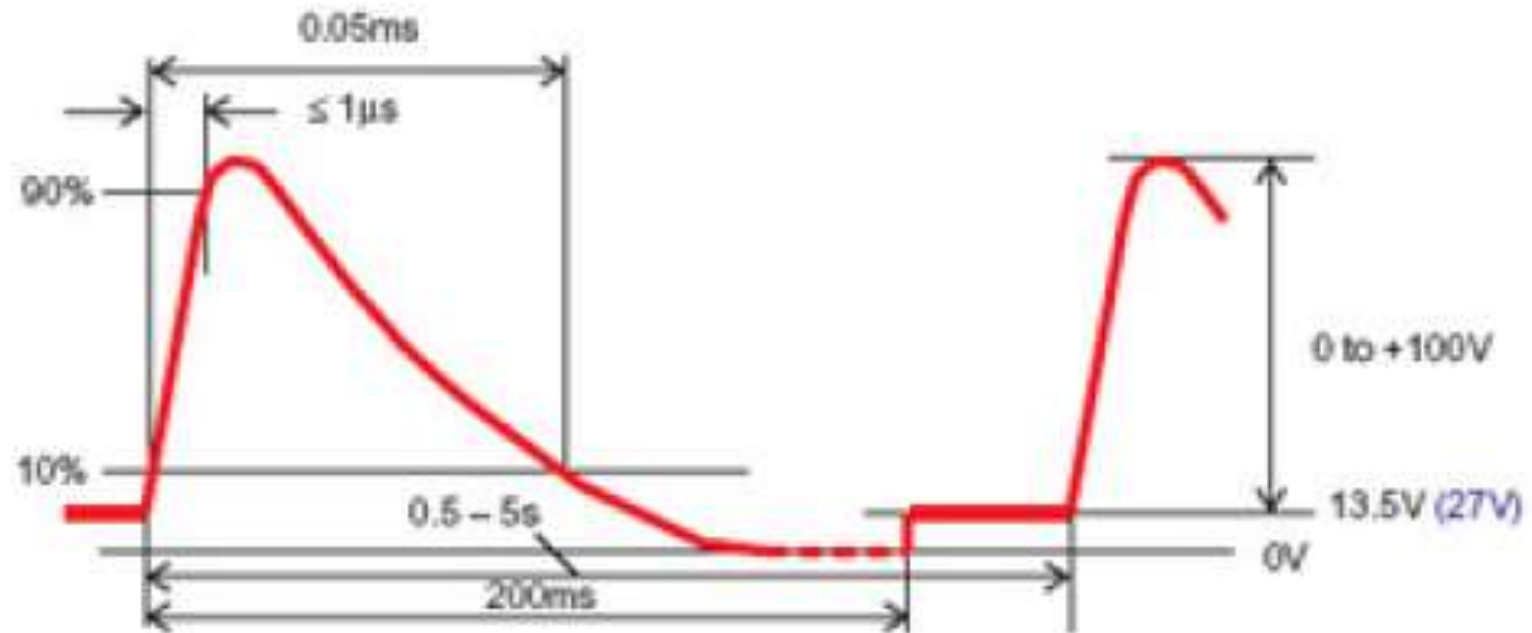

NASTY ELECTRICAL BEHAVIORS

- ▶ Common occurrences on the main power line in a car

Load connections / disconnections and cabling/harnesses

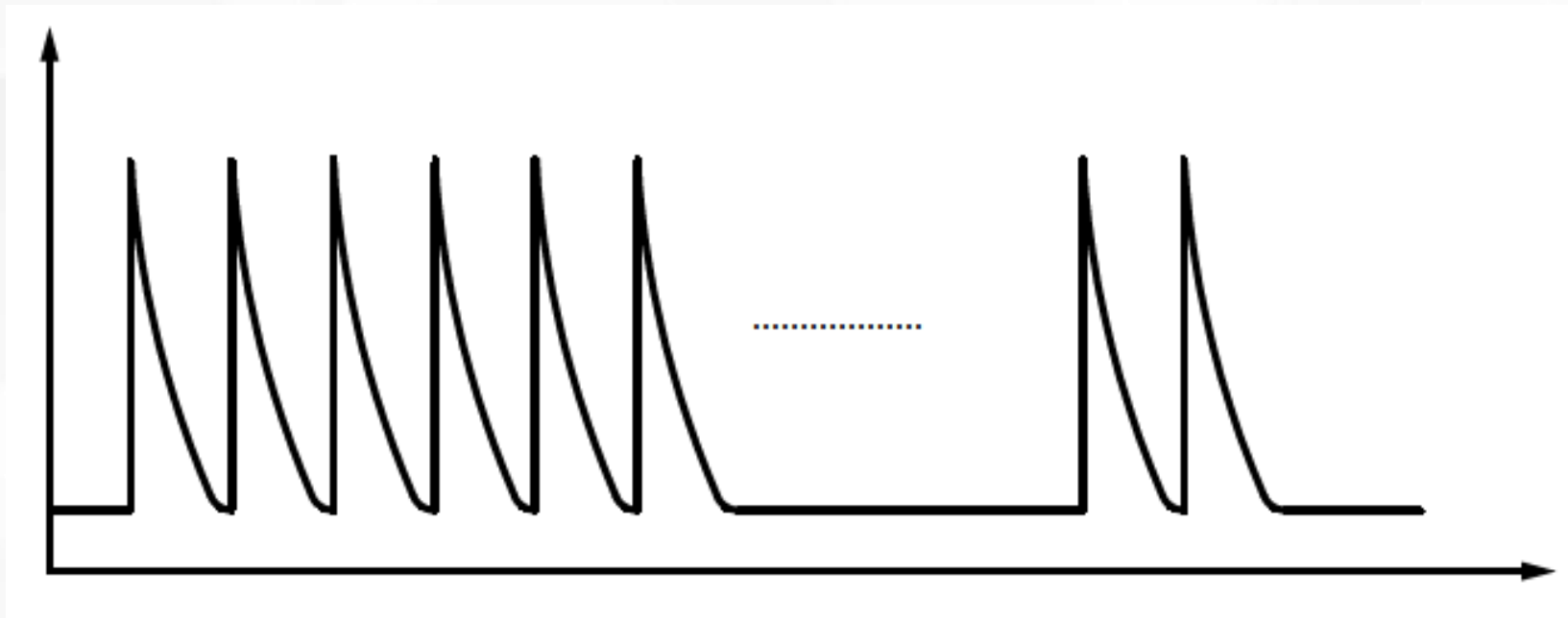

AUTOMOTIVE "TORTURE TESTS"

Slow Vbatt Rise & Fall

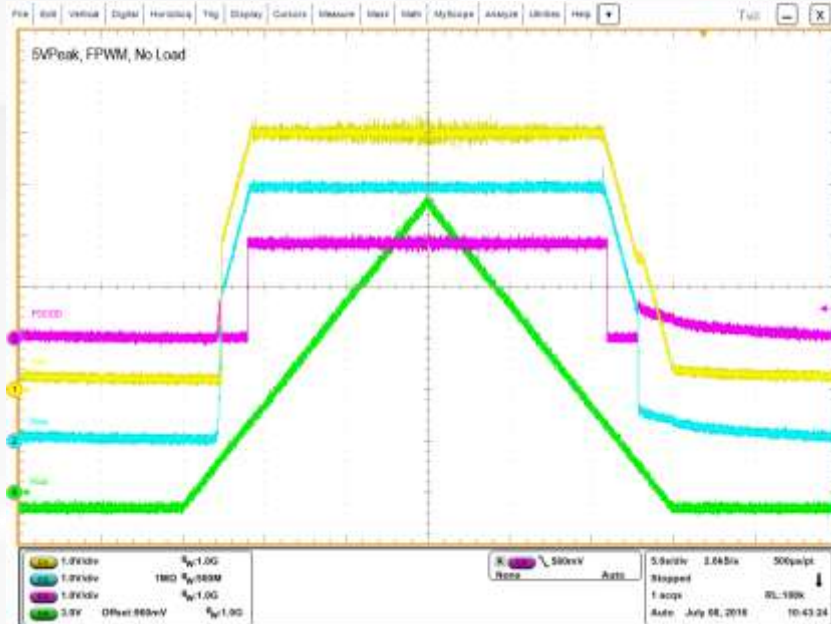

Load Dump

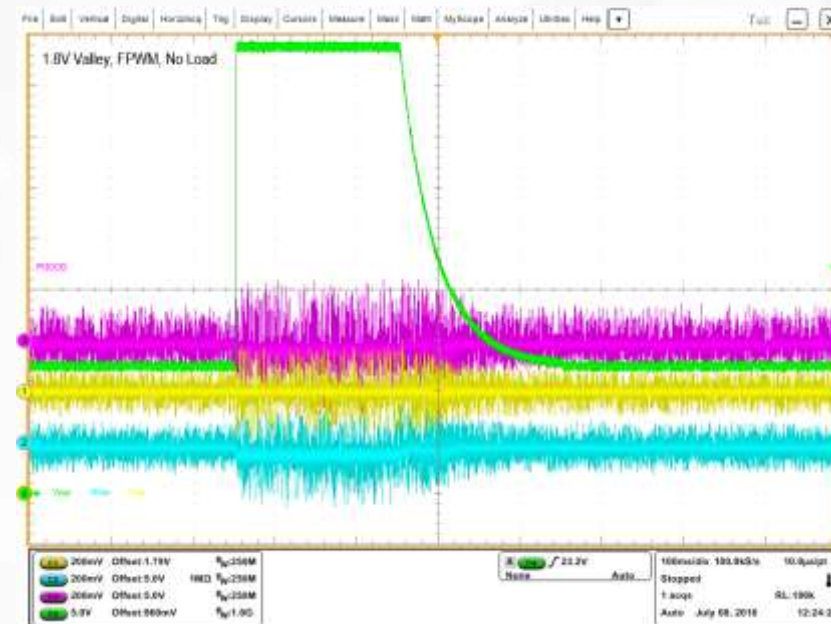

ELECTROMAGNETIC COMPATIBILITY

MEASURING EMC

- ▶ **Official Automotive Standard is CISPR 25**
 - Need dedicated EMC testing setup
 - Usually go to a certified lab with equipment
- ▶ **Conducted Emissions**
 - 150kHz – 108MHz
 - Positive and Negative lines
- ▶ **Radiated Emissions**
 - Rod Antenna (0.15 – 28MHz) – AM band
 - Bicon Antenna (30-200MHz) – FM band, Mobile Services, TV Band
 - Log Antenna (0.2-1GHz) – Mobile Services, TV Band
 - Horn Antenna (1.8-2.5GHz) – Mobile Services, GPS

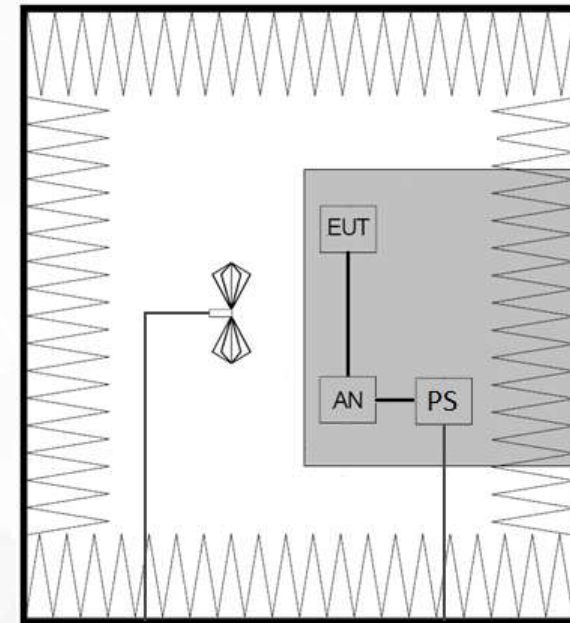

Radiated Emissions Test Setup

Image: CISPR 25, adapted; Fair Use asserted

Our Product Strategy



High Performance:
High efficiency
Low Iq
Low noise

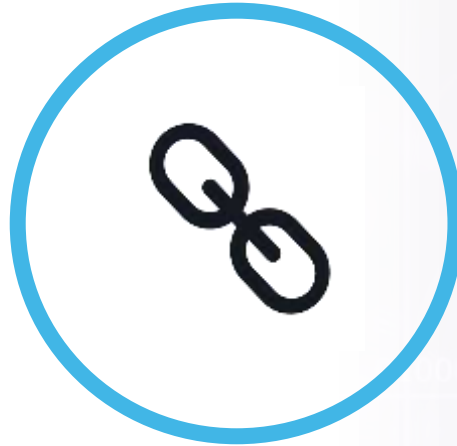

ASIL solutions for ADAS



Trusted Advisor & Joint Definition



Scalable high-power density

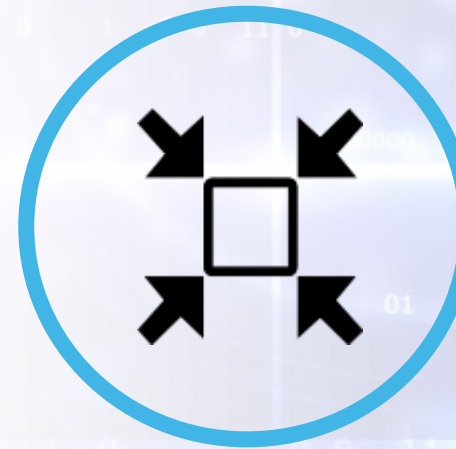

Small sol. size & BOM optimization



ADI AUTOMOTIVE POWER FEATURES

2MHz+ Fsw Capability

- Requires $< 80\text{nS}$ Min_On
- 60% smaller footprint
- Avoids AM radio interference
- Faster load transient response

High Efficiency

- Fast switching - Integrate Mosfets
- FCQFN reduce the parasitic
- Ultra low Iq

Integration

- Internal compensation
- Fixed output – No external R
- Internal Soft Start
- Smaller output capacitor

Family of DC/DC converters

- P2P compatible series
- Support the stackable
- Easy adjustment

ADI AUTOMOTIVE POWER: FUNCTIONAL SAFETY

- ▶ Maxim has the capability to develop ASIL-D power solutions
 - Product development based on ISO26262 standard
 - Independent quality team performs functional safety assessment at defined stages according to ISO26262
 - Dedicated functional safety development procedure & safety plans
- ▶ Functional safety product customer support & collateral
 - Safety manual
 - Customer review of collateral such as FMEDA, hazard analysis, safety concept, etc.
 - Development interface agreement/DIA, if mutually agreed

FCQFN (FLIP CHIP) WITH COPPER PILLARS

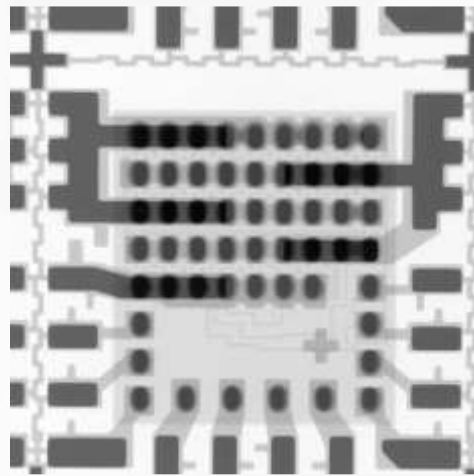
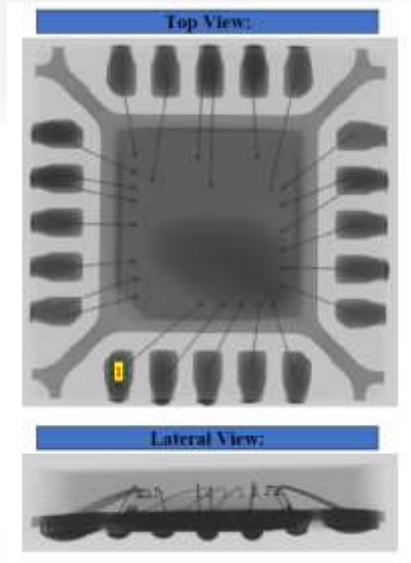
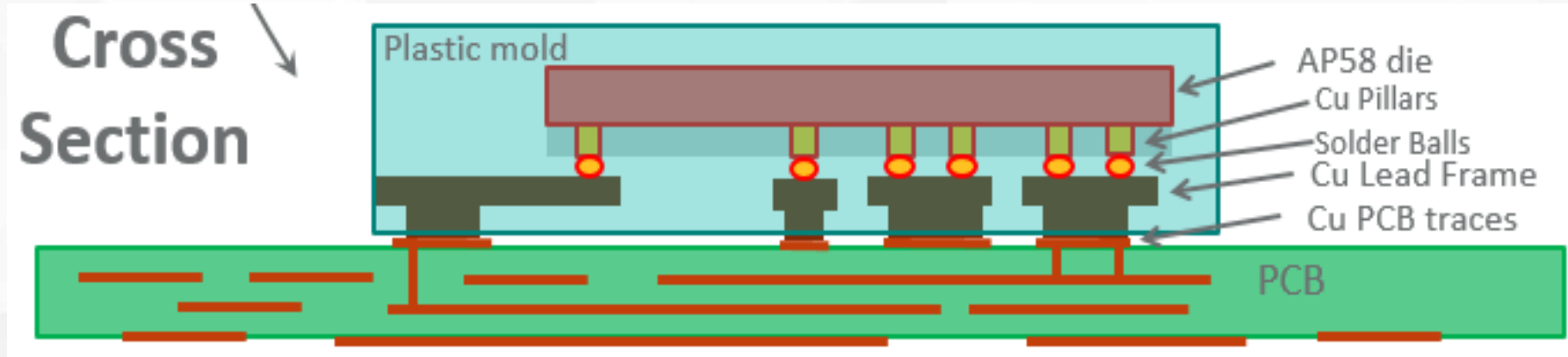

- Cu pillars replace bond wires →

 - Low parasitic L & C
 - Lower EMI
 - Higher efficiency
- Multiple pillars for FET leads →

 - High current and high power-density
 - Comparable thermal performance to standard QFN with heat pad
- Multiple package vendors in mass production →

 - Economy of scale and cost

Table of Contents

Overview

- ▶ [High Voltage Buck Converters](#)
- ▶ [High Voltage Buck Controllers](#)
- ▶ [Buck-Boost Converters and Controllers](#)
- ▶ [Boost Converters and Controllers](#)
- ▶ [LDOs](#)
- ▶ [Isolated Flybacks](#)
- ▶ [Low Voltage PMICs](#)
- ▶ [Camera PMICs](#)
- ▶ [ADAS PMICs](#)
- ▶ [Phantom Power & Diagnostics](#)
- ▶ [ASIL Monitors](#)
- ▶ [SOC Power](#)
- ▶ [Telematic Solutions](#)
- ▶ [Appendix](#)

High Voltage Synchronous Buck Converters

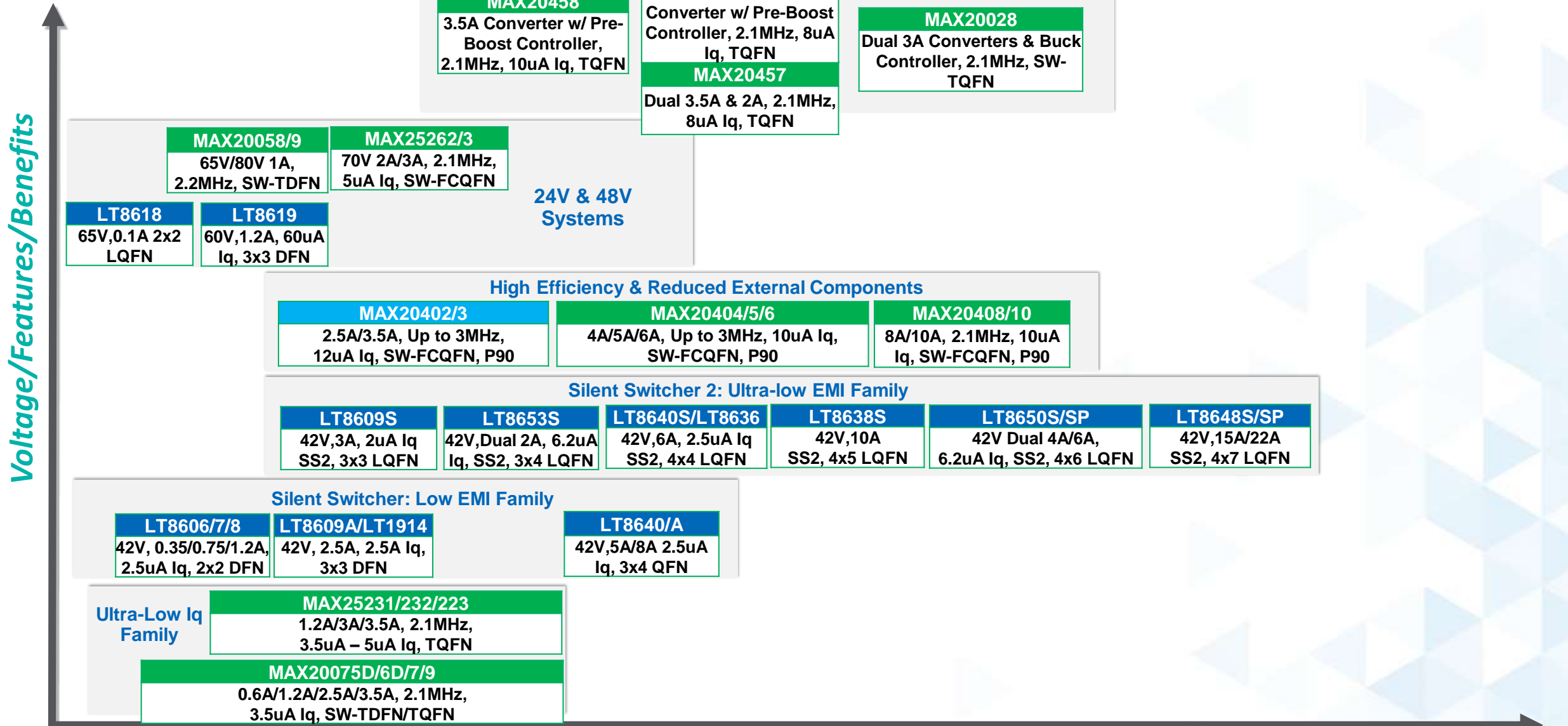

High Voltage Buck Synchronous Controllers

Voltage/Features/Benefits

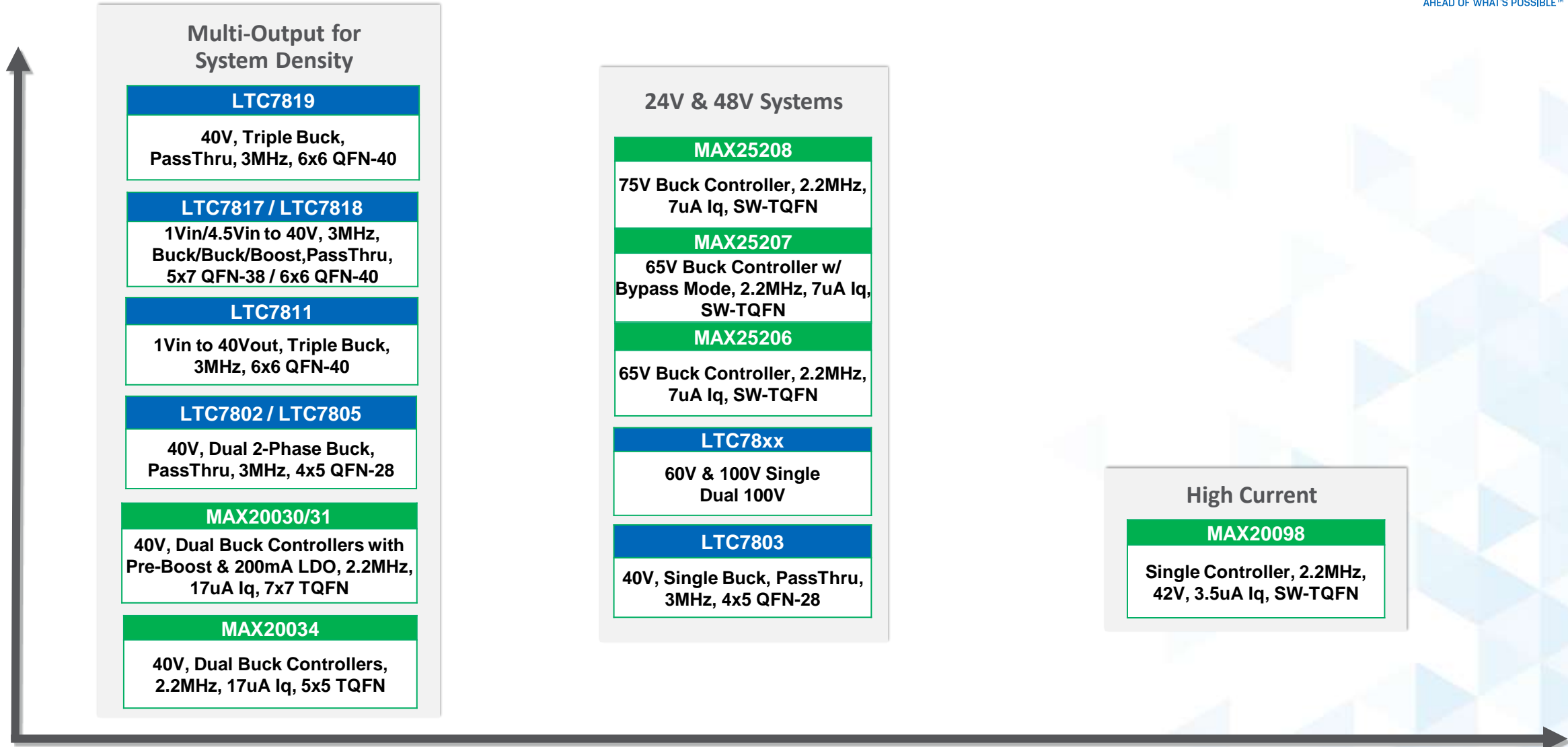

Load Current

Production

Production



High Voltage Synchronous Buck-Boosts

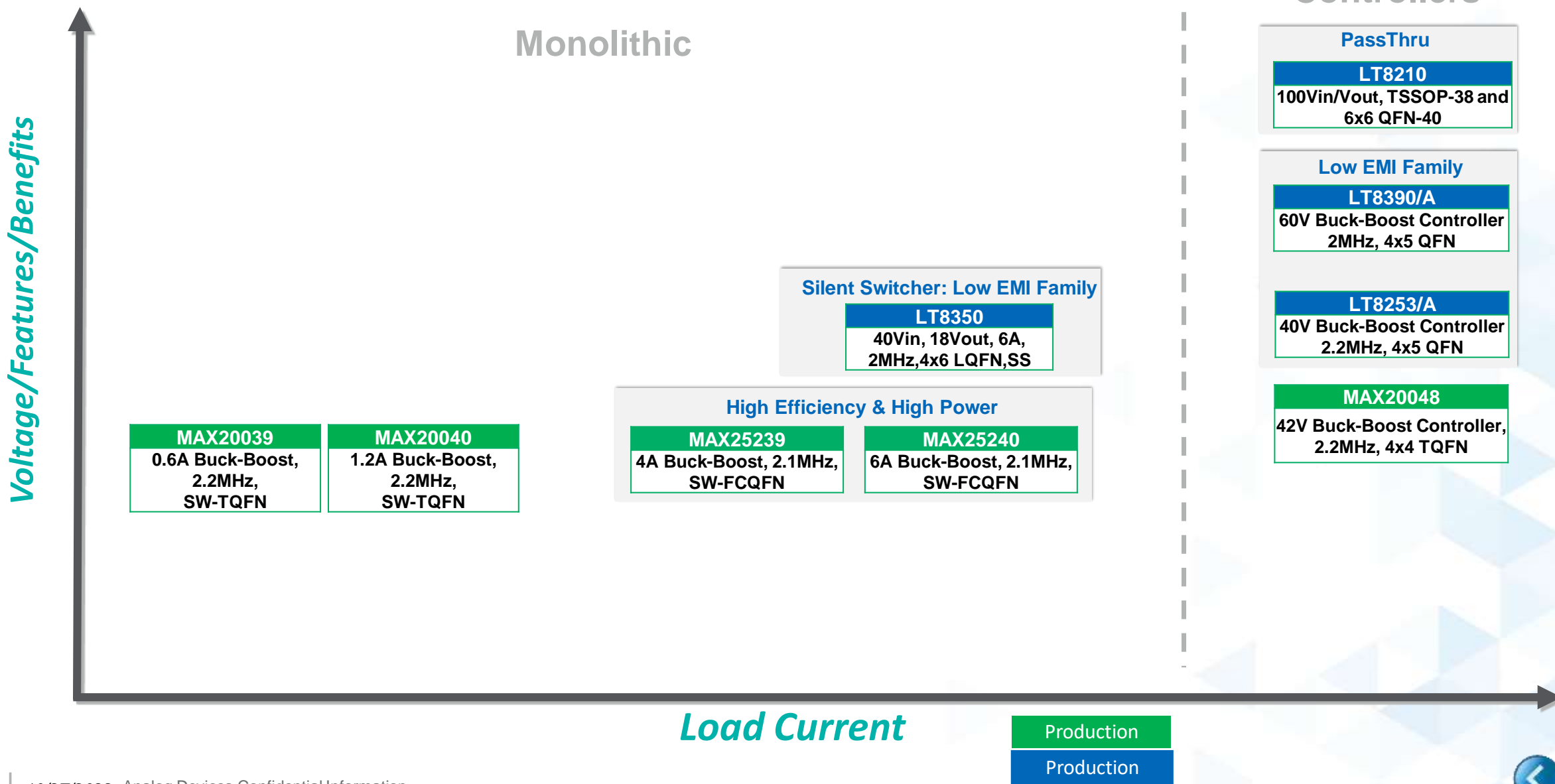

High & Low Voltage Boost

Controllers & Converters

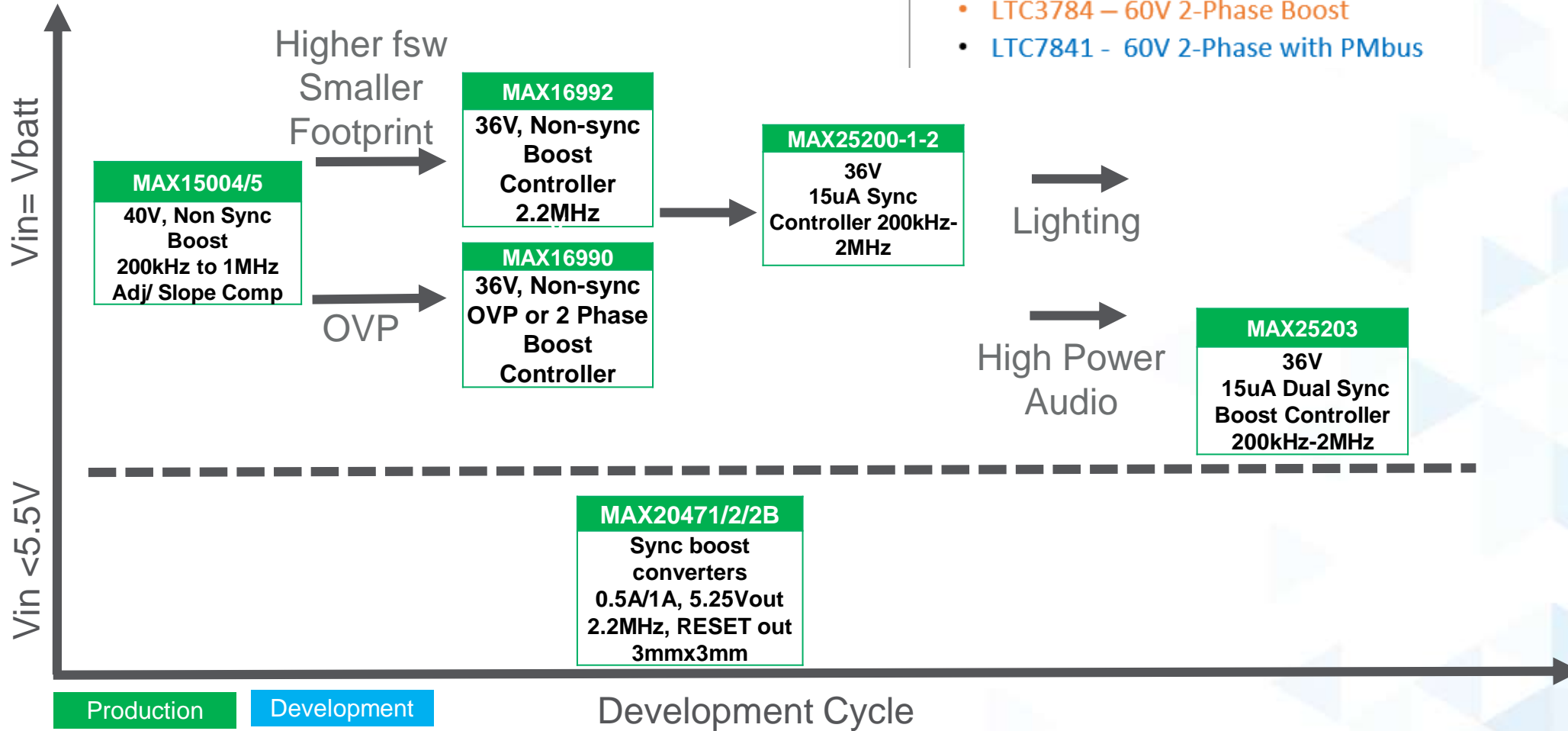

Synchronous Boost Controllers

- LTC7804 – 40V
- LTC7806 – 40V 2-Phase (Released)
- LTC3787 – 40V 2-Phase Boost
- LTC3769 – 60V Boost
- LTC3784 – 60V 2-Phase Boost
- LTC7841 - 60V 2-Phase with PMbus



Automotive LDO Roadmap

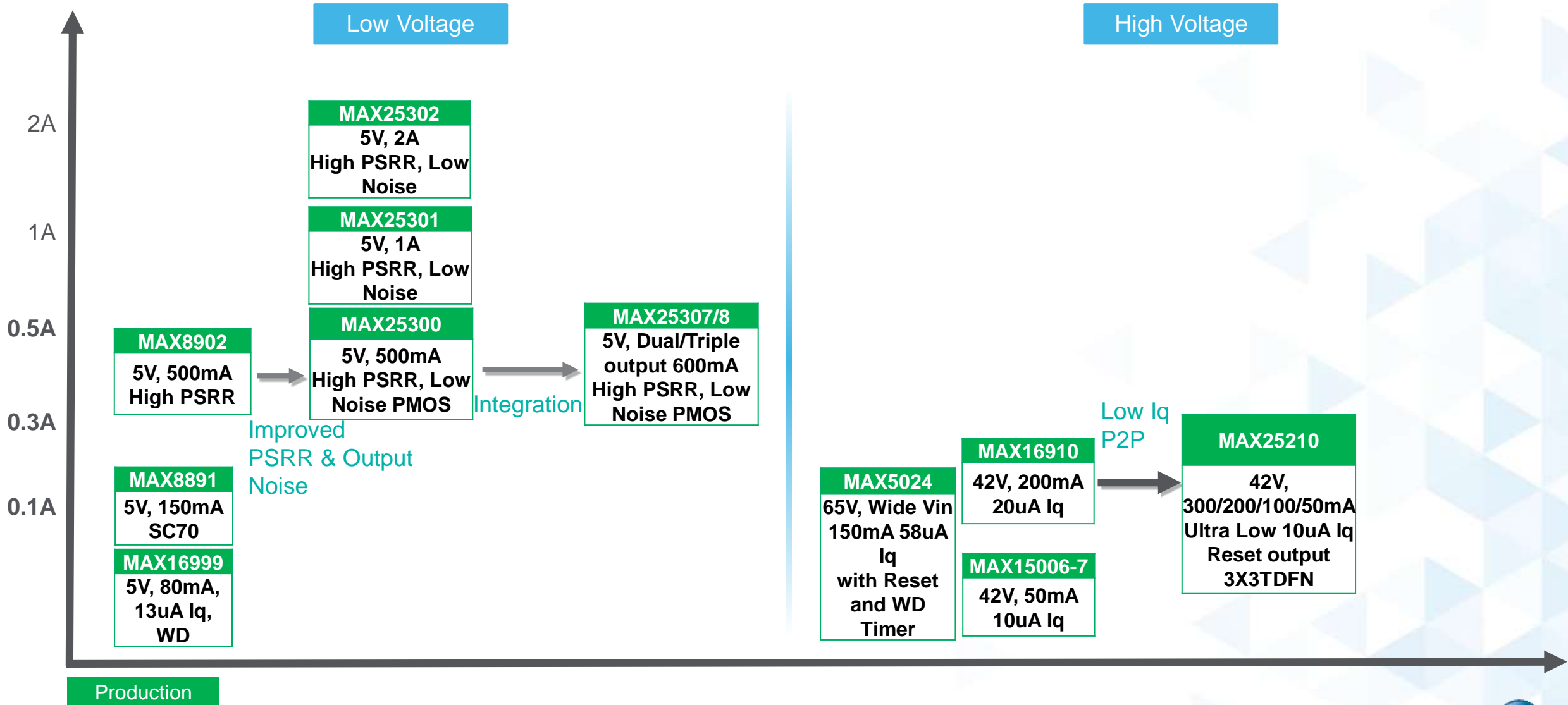

Isolated Flyback Converters & Controllers

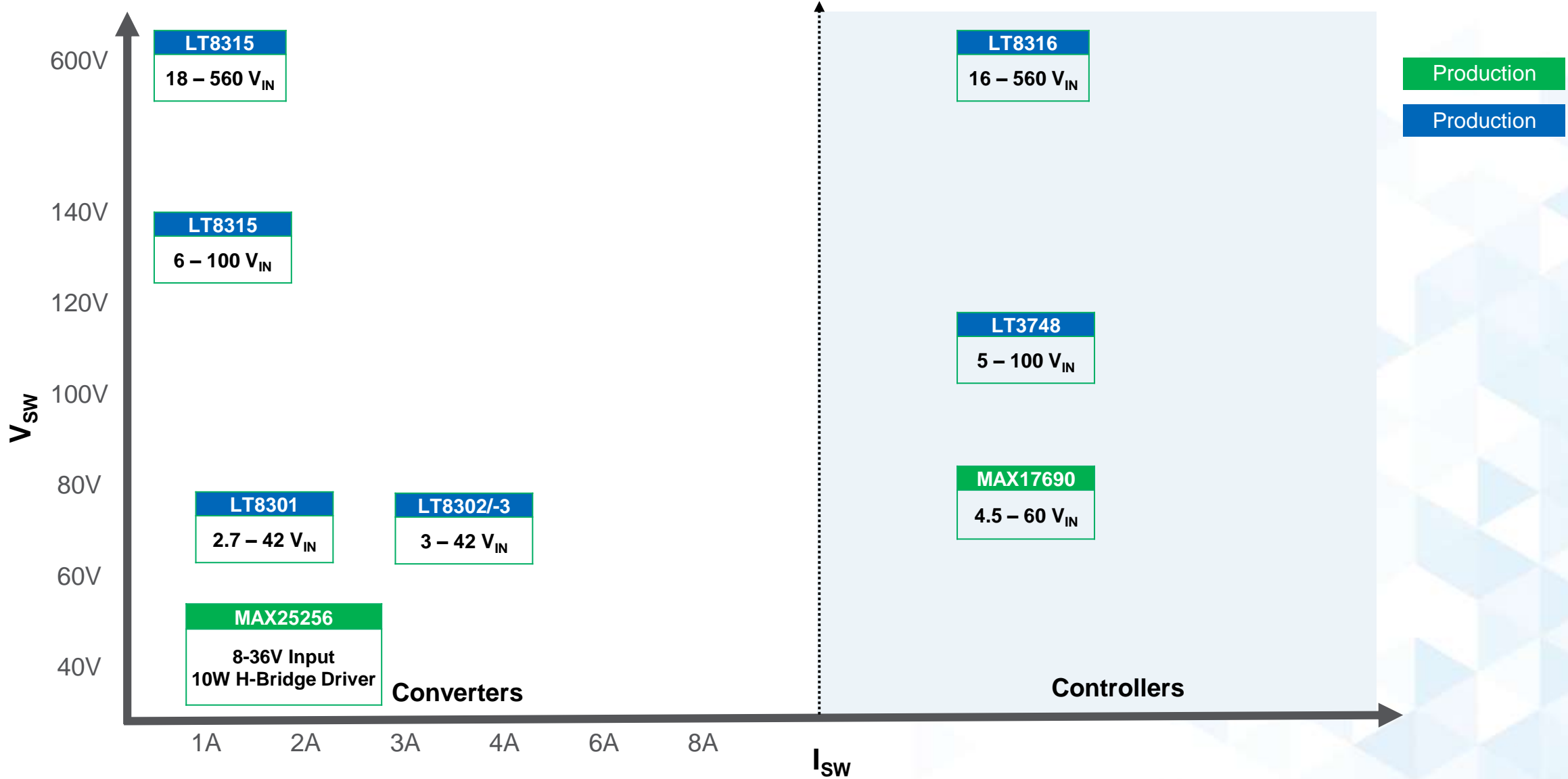

EV/HEV & Truck Converters and Controllers

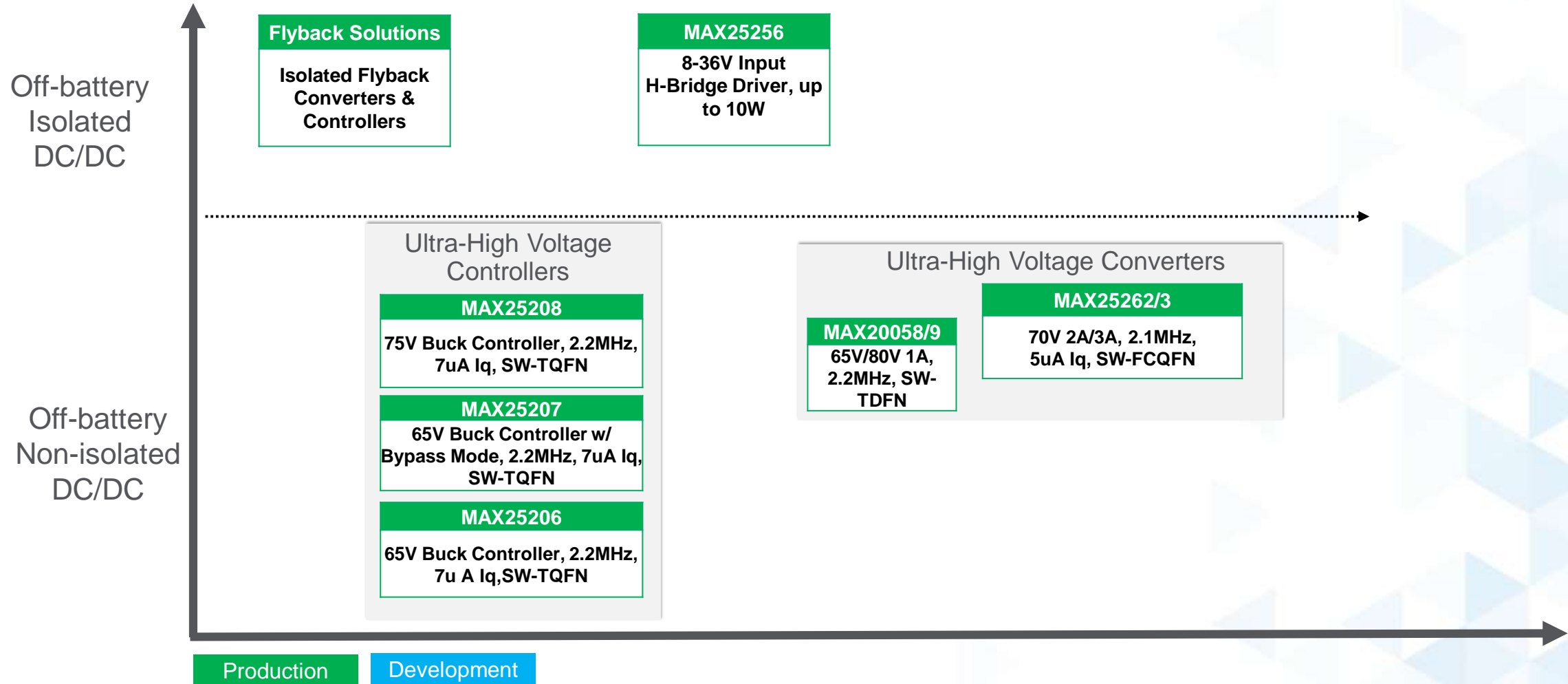

Low Voltage PMIC Roadmap

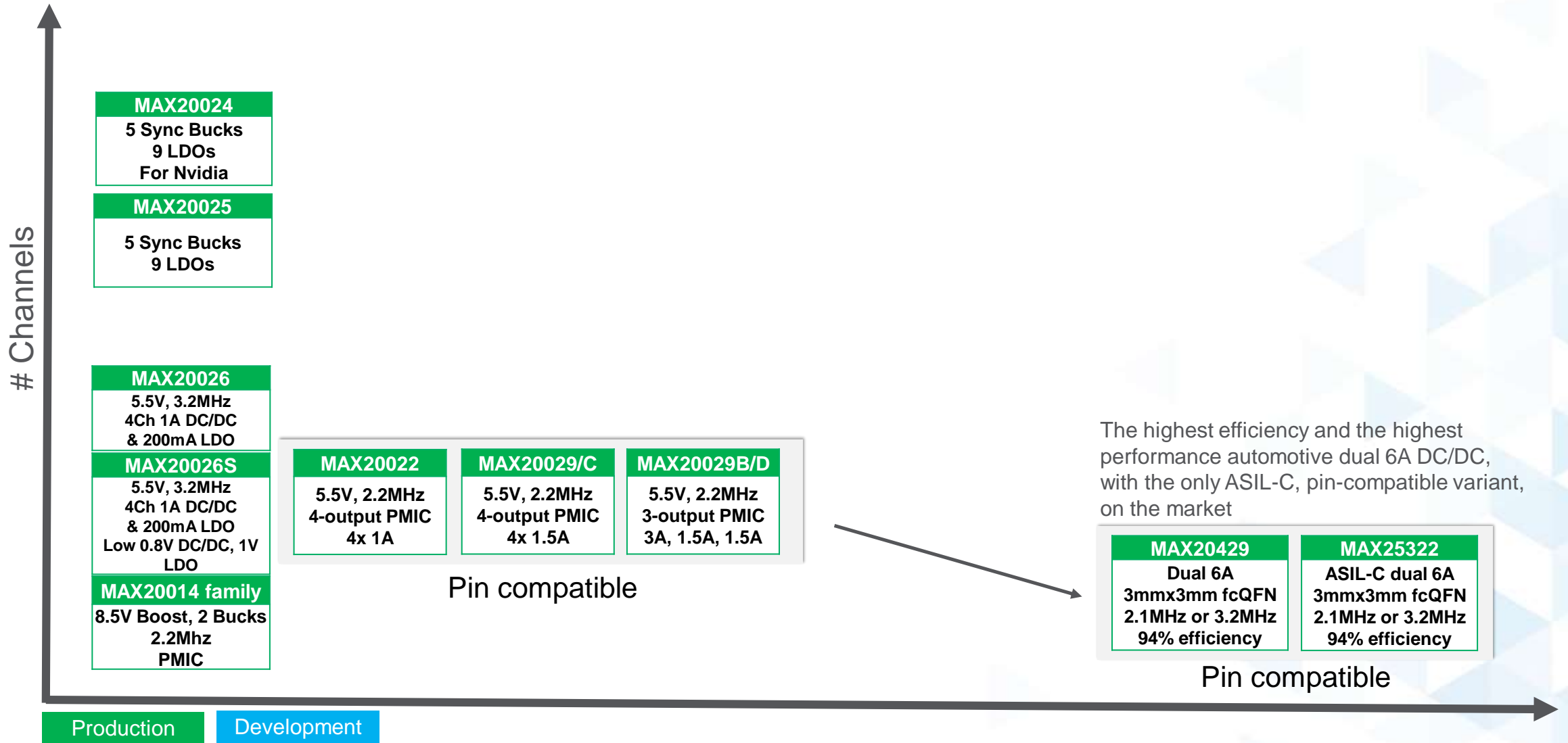

Camera Sensor Power & Protection Roadmap

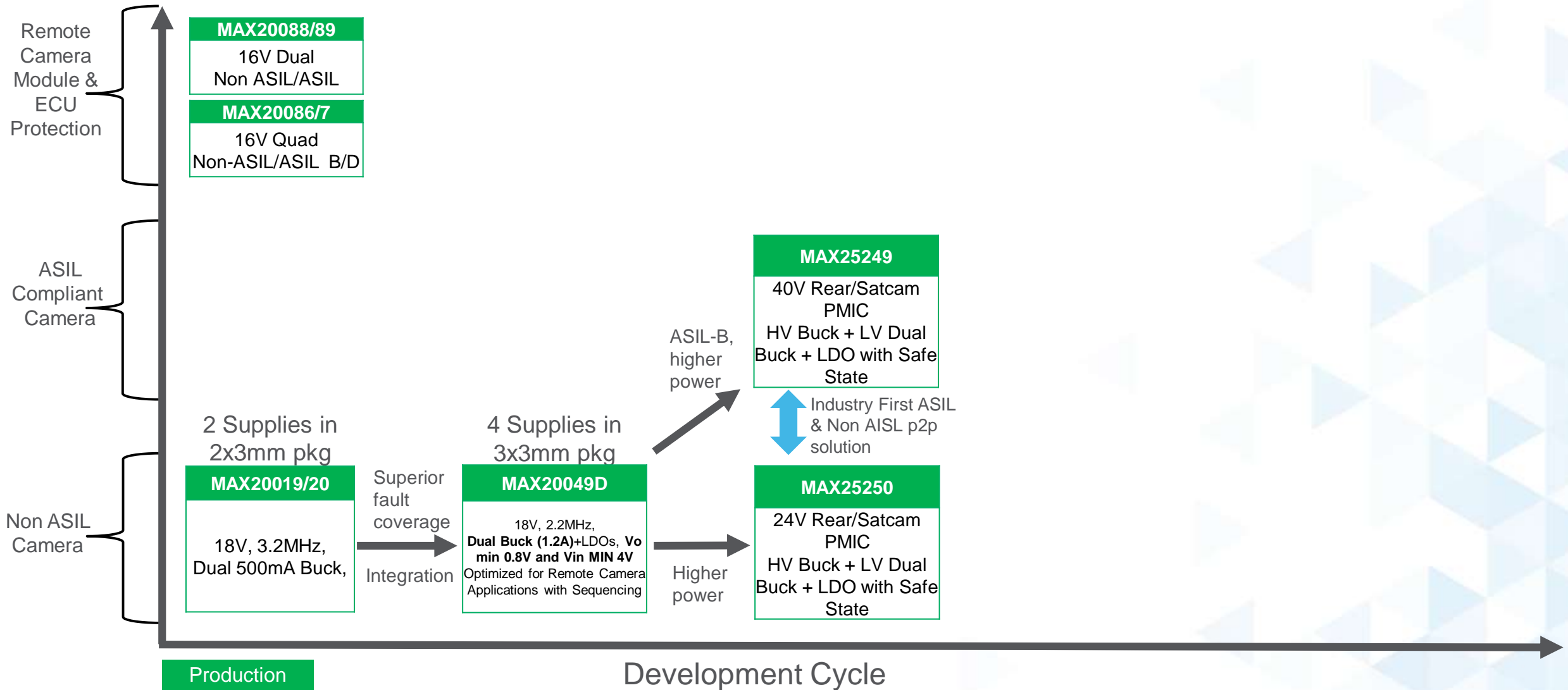

ADAS PMICs: SoC, Radar Sensor & Front Camera Module Power

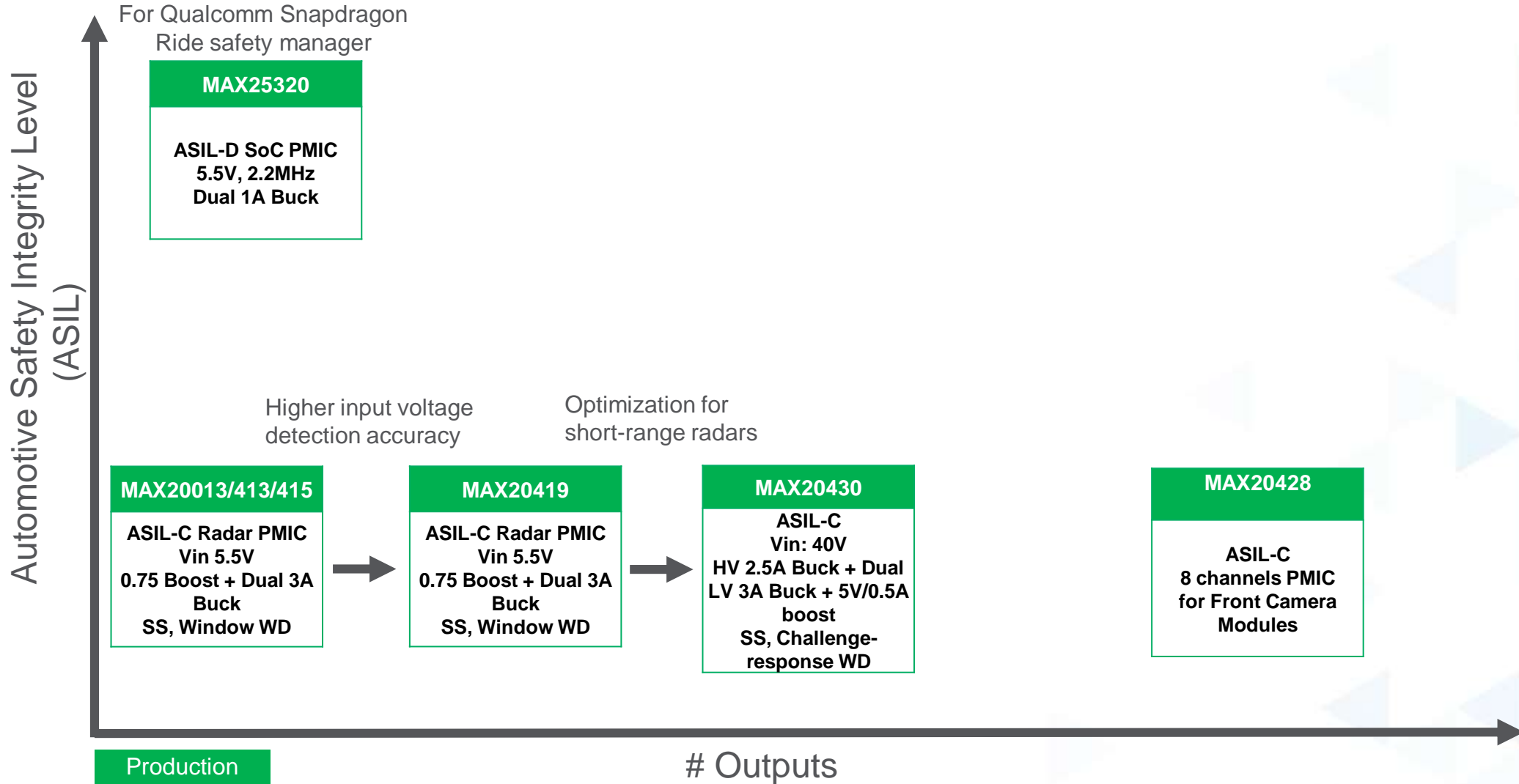

Phantom Power and Diagnostics

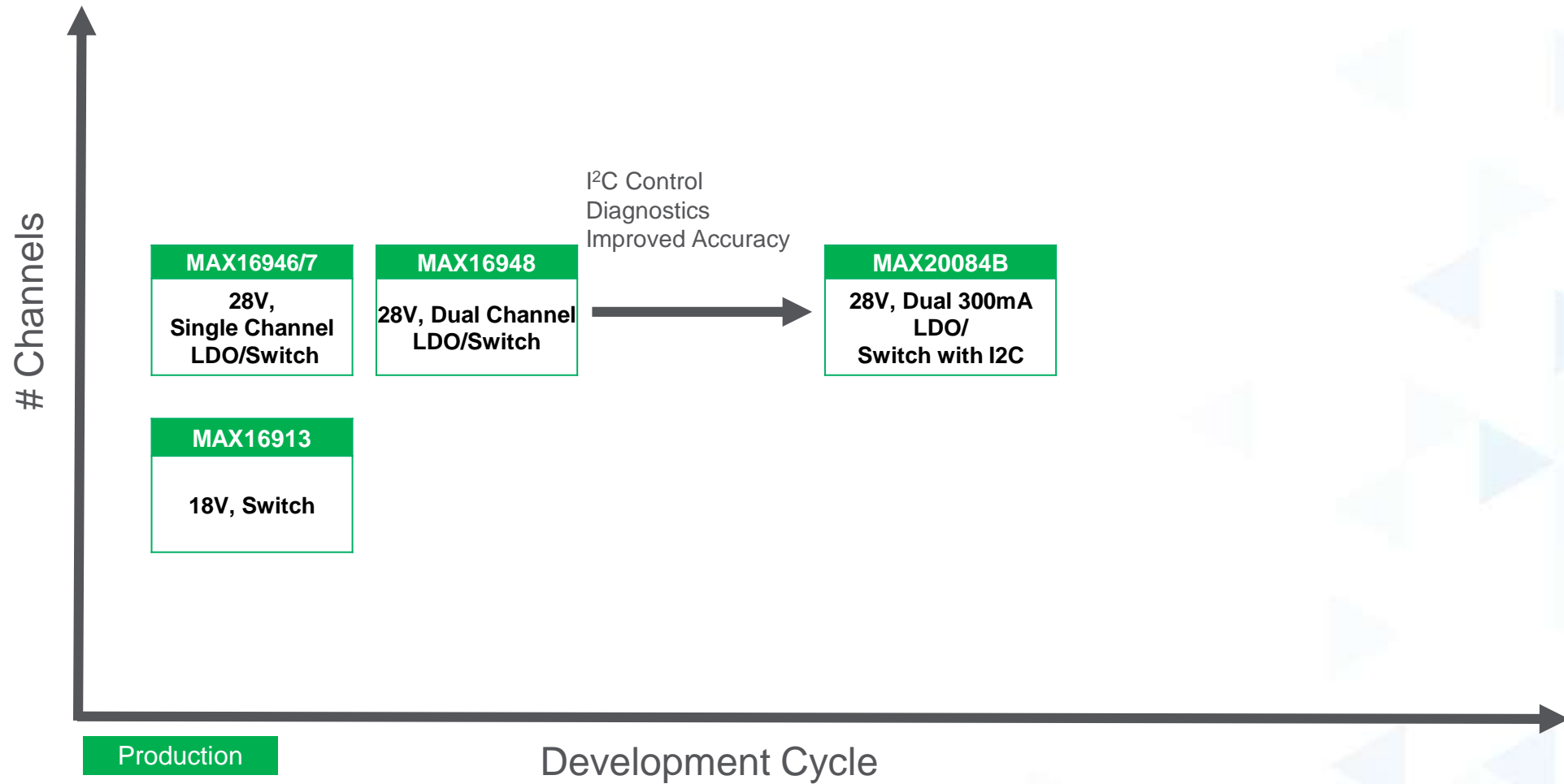

ASIL-Compliant Power System Monitors

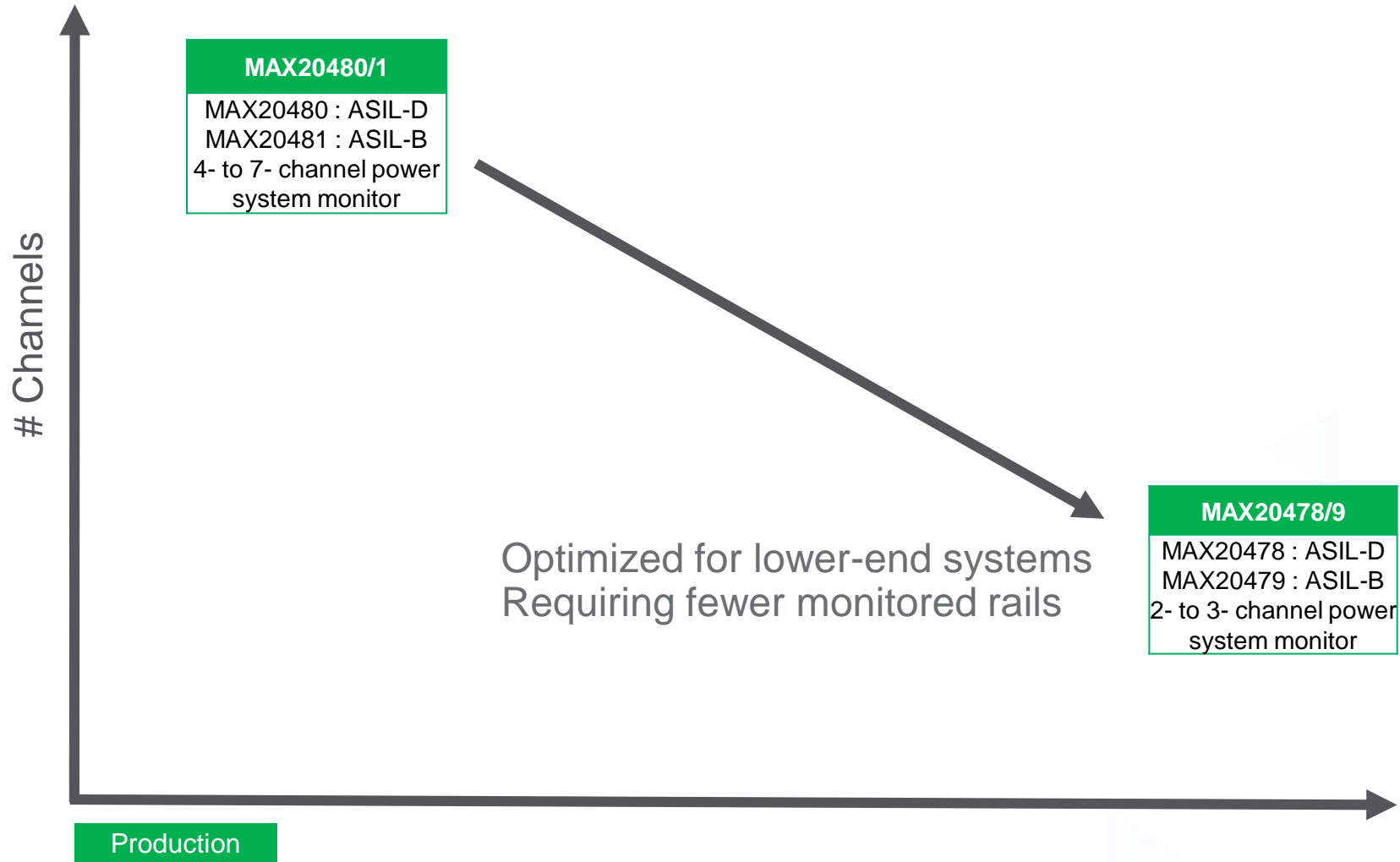

SoC Core Power Solutions

